

# GEAR TECHNOLOGY

March/April 2011

[www.geartechnology.com](http://www.geartechnology.com)

The Journal of Gear Manufacturing

## Feature Articles

- Induction Hardening Technology
- New Grinding, Finishing—and Profit—Advancements
- New Turbine Gearbox Standard—An Update

## Technical Articles

- Face Gears
- Gear Measuring Machine by “NDG Method” for Gears Ranging from Miniature to Super-Large
- Optimal Modifications of Gear Tooth Surfaces

## Plus

- Addendum: The Gear Ring

# Induction Heat Treating

## Gains Ground through Advances in Technology

William R. Stott, Managing Editor

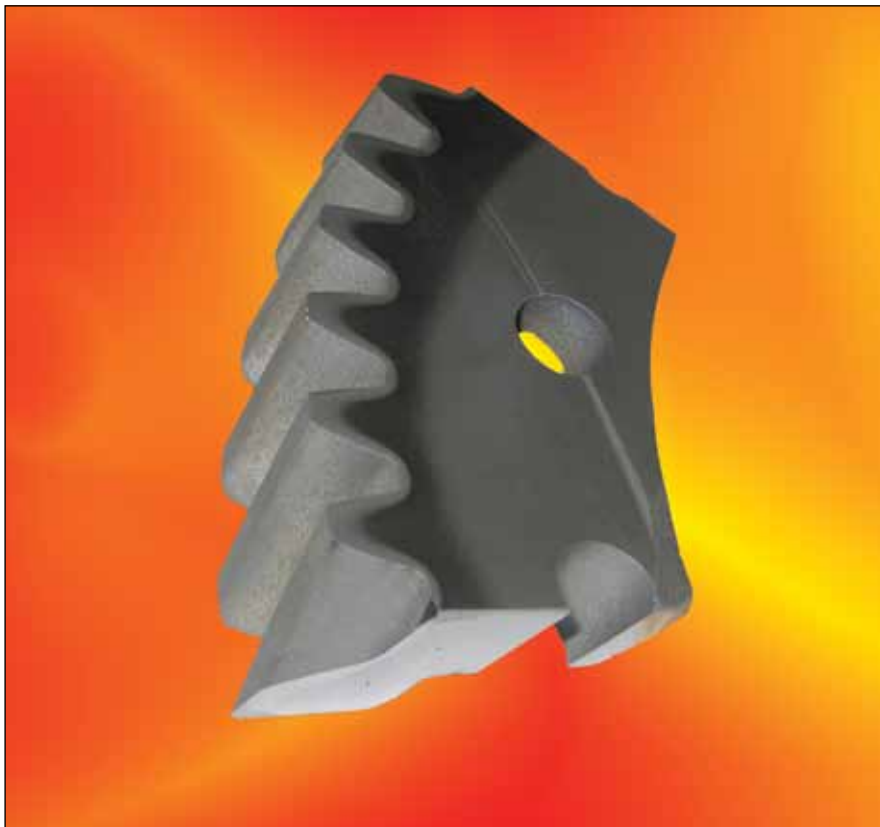

**This cutaway shot shows the heat treat and quenching pattern of a spur gear induction hardened with the TSH technology (courtesy of ESR Engineering Corp., the North American distributor of TSH steels).**

In recent years, there has been significant interest in expanding the use of induction hardening in gear manufacturing operations. One of the reasons is that induction hardening is easily incorporated into a manufacturing cell. Parts don't have to be taken out of the production flow and sent to a separate heat treating department. Another reason is that induction hardening is often considered a "green" alternative.

"Induction continues to have advantages that include precise heat-

ing of just the are requiring heat treat, thus minimizing the energy applied to the part," says George Welch, manager of heat treat products for Ajax-Tocco Magnethermic. "In addition, induction does not consume energy when idle. Combine this with reduced energy for auxiliary equipment for quenching, etc., energy usage and costs are generally much less. Other advantages include fast processing time, fewer parts in process, cell manufacturing, less distortion and individual part

traceability."

In the past, the problem was that induction hardening was limited in its potential applications. Only certain gear shapes and configurations were good induction hardening candidates. If you wanted to case harden a spiral bevel automotive pinion, for example, carburizing has long been the practical choice.

Also, induction hardening has been possible only with certain steels.

**continued**



**Tooth-by-tooth induction hardening is often used for larger gears. Modern machines are equipped with sophisticated controls and software, allowing precise control over the hardness pattern and tooth-by-tooth documentation for quality control (courtesy Ajax Tocco Magnethermic).**



**Induction Heating a large Caterpillar gear for hardening (courtesy of Caterpillar, Inc. and Ajax Tocco Magnethermic Corp).**

Typically this has meant both plain and alloy medium-carbon steels with 0.4 percent to 0.6 percent carbon content, according to Dr. Valery Rudnev, group director of science and technology for Inductoheat.

Furthermore, induction heat treating machines have often been designed for specific gear parts or a limited range of parts. Each part often requires customized tooling, and a power supply (or power supplies) that provide the necessary power and frequency to achieve the desired heating pattern. These systems have limited flexibility.

But over the past several years, many of the limits to induction hardening have shrunk, thanks to recent advances in technology, materials and processing techniques.

#### **Power Supplies**

The heart of an induction hardening system is the coil, but its brains are the power supply and controls. In recent years, these are the areas where induction hardening technology has improved the most.

“The power supplies have continued to advance and provide new solutions for heat treating parts including gears,” says Welch. “Higher power and greater frequency flexibility allow for high power densities at the ideal heating frequency. This aids in processing a greater range of gear sizes and pitches. In addition, advancements in controls allow for better tracking of the entire heat treat process.”

Inductoheat’s Rudnev agrees that power supplies have been an area of significant advancement. In fact,

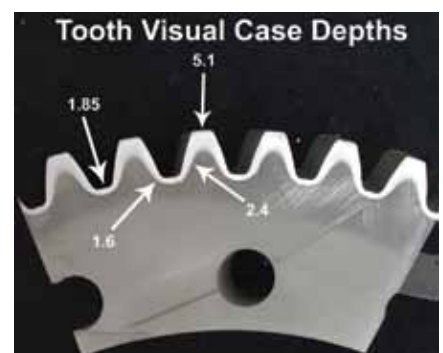

**New steels and processing techniques allow case hardening of gears by induction at a much lower cost and with less energy consumption than previous technologies (courtesy ESR Engineering Corp., North American distributor of TSH steels).**



**TSH technology allows difficult components, such as spiral bevel gears and pinions, to be heat treated via induction. Most of these gears are currently carburized (courtesy ESR Engineering Corp., North American distributor of TSH steels).**

Rudnev says, Inductoheat has recently introduced power supplies that significantly increase the flexibility of induction hardening systems by providing the unique capability of controlling not just an inverter's output power, but also its frequency, in a manner similar to the control of CNC machines.

Whereas previous generations of power supplies had limited flexibility, Rudnev says, the current generation can produce a high-end frequency up to eight times as great as the low-end frequency. What this allows, Rudnev says, is expanding the range of gears to be induction hardened using the same power supply and/or tempering of a part in the same setup as hardening.

"The majority of gears are tempered in ovens," Rudnev says, "but we were able to develop a new power supply that allows induction hardening and tempering at optimal frequencies."

For example, with the new power supply, you can "dial" a frequency of 40 kHz to induction harden a fine-tooth gear. Then you can dial it down to 6 kHz to temper it at low frequency.

"Inductoheat's Statitron-IFP power supply technology provides a wide range of frequencies," Rudnev says.

The same capability also allows the same machine to induction harden different pitch gears.

The use of simultaneous dual-frequency induction hardening is a proven way to effectively control distortion when induction hardening small and

medium size gears using encircling inductors. In many cases, simultaneous dual-frequency technology allows keeping distortion after induction hardening within the range of 80–100 microns, Rudnev says.

Increasing the frequency range of power supplies has also been on the mind of designers at Ajax-Tocco Magnethermic. "Induction systems can be designed to heat treat a range of part sizes and families with tooling changes," says Welch. "Power systems can

be provided with wide frequency ranges and load matching capability to process a variety of case depth requirements."

In addition, Welch says, larger power supplies have enabled induction hardening of larger gears.

#### Controls

Of course, like all machine tools, induction hardening machines have benefited from advances in control technology and software.

"Large gears are generally hard-

**continued**



#### FOR DECADES

Fässler AG has been considered to be the world's market leader in honing technology. Innovative, high-precision and sustainably designed honing systems are developed in real time regardless of the complexity of requirements. Constant movement is the creed that is adhered to in all the corporate divisions of Fässler AG.

Renowned corporations on the world market rely on honing to Swiss perfection. Cog by cog. Perfect to the very last detail.

**Fässler**  
Honing to Swiss perfection

Faessler Corp. | 131 W. Layton Ave., Suite 308 | Milwaukee, WI 53207-5941 USA  
www.faessler-usa.com | +1 414 769 0072

## LOOK WHAT'S COMING YOUR WAY.

A new state-of-the-art ground gear production facility for heavy-duty trucking applications will be opening later this year. South Bend Gear, LLC. A joint venture combining the expertise of two of the most progressive gear manufacturers in the world, South Bend Gear will be here soon. Look for it.



SOUTH BEND  GEAR, LLC

A joint venture of Schafer Gear Works and Somaschini, S.p.A  
southbendgear.com • 574-234-4116

ened with the tooth-by-tooth method,” Welch says. “This process was developed about 60 years ago. The newest machine controls include recipes that precisely locate the gear tooth and provide motions to scan harden OD, ID, spur and helical gears.”

Furthermore, the controls and software provide important quality control data.

“These systems collect the process information available for each tooth for traceability of each gear heat treated,” Welch says.

### Materials

Induction hardening is generally limited to certain types of steels. Unlike carburizing, during which carbon is infused into the part, induction hardening requires higher-carbon steels to begin with. Typical induction hardening steels include AISI 4140, 4340, 1045, 4150, 1552 and 5150, Rudnev says.

But new advances in materials have opened up new applications to induction hardening. One example is the range of TSH steels available exclusively from ERS Engineering Corp. ERS has worked with its European partners to develop the steel metallurgy and process that will allow induction hardening to replace carburizing for a wide range of parts, including parts previously thought to be impossible to induction harden successfully.

Inductoheat has been chosen by ERS to be their exclusive manufacturer of induction heat treating systems for TSH technology in the North American market.

The latest TSH steels are low-alloy carbon steels, which are characterized by reduced grain growth during heating into the hardening temperature range. They can be substituted for more expensive standard steels typically used for conventional induction hardening or carburizing.

TSH steels have significantly less alloying elements such as manganese, molybdenum, chromium and nickel, making them less expensive than conventional carbon steels, Rudnev says. “Their chemical composition is somewhere between micro-alloy steels and plain carbon steels, providing fine-grain martensite with extremely high compressive stresses at the tooth surface.”

### Correction:

*In the January/February issue of Gear Technology, a photo caption incorrectly identified a Mazak machine as a Depo machine (Bottom photo, page 30) in the article, “The Merits of Multifunctional Machining.”*

*Gear Technology regrets the error.  
—The Editors*

### Clarification:

*A statement appears on page 77 of the Jan/Feb gear schools article—“Now, More than Ever”—that may have been misleading to readers. In the second complete paragraph, a quote attributed to Geoff Ashcroft of the Gear Consulting Group (GCG) includes the word “certification.” To be clear, the AGMA board has made a conscious decision not to have a certification program at this time, due to certain liability issues. The course Geoff Ashcroft instructs is indeed licensed to GCG by AGMA, but participants receive a certificate of completion, which of course is not AGMA certification.*

*Gear Technology regrets any resultant confusion.  
—The Editors*

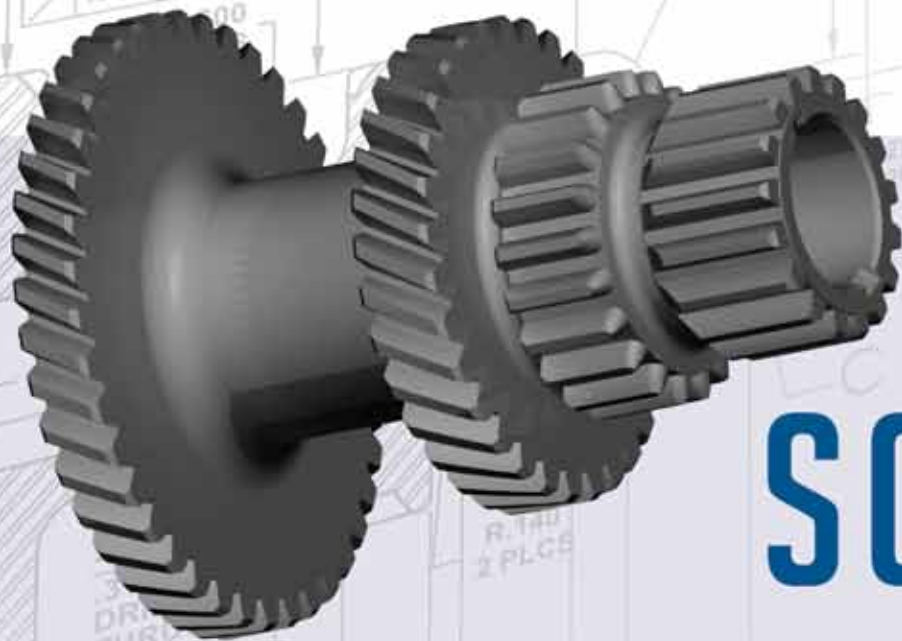

WHEN PLANNING  
YOUR NEXT PROJECT

**THINK  
SCHAFER**

## We have the solutions to put your best ideas in motion.

At Schafer Gear, we're always impressed by the incredible designs that come from our clients. Our job is to help put these great ideas in motion with equally well-engineered gear solutions. That's why it's never too early to think Schafer. Not only will we work with you to identify the solutions that precisely match your project requirements, but we also promise to deliver exceptional quality and unmatched responsiveness to your every need.

**FIND OUT MORE** at [www.schafergear.com](http://www.schafergear.com)  
or give us a call at 574-234-4116





**With TSH technology, parts are induction heated at low frequency and rapidly quenched, resulting in a contour induction hardening pattern (courtesy ESR Engineering Corp., North American distributor of TSH steels).**

The combination of the new steels with the right technique has even opened up the application of induction hardening to such difficult parts as spiral bevel automotive pinions.

“In the past, all of those parts used to be carburized,” Rudnev says. “Due to a combination of shape complexity and gear sizes, it was practically impossible to induction harden those parts. Now it is possible to get those beautiful hardness patterns on complex-shaped gear parts by through-heating those parts using low frequency inverters.”

With TSH technology, after through heating, the parts are rapidly quenched. The hardened depth is mainly determined by the steel’s chemical composition and initial microstructure.

Also, because the parts are through-heated using a low frequency (1–25 kHz, depending on the application), the cost of capital equipment is also low, Rudnev says.

The TSH technology is extremely promising, due to the obvious cost savings and its applicability to the “lean

and green” approach, Rudnev says. “I do believe that this technology has a very bright future in the North American Market.” ⚙

**For more information:**

Ajax Tocco Magnethermic Corp.  
1745 Overland Ave.  
Warren, OH 44483  
Phone: (800) 547-1527  
Fax: (330) 372-8608  
[info@ajaxtocco.com](mailto:info@ajaxtocco.com)  
[www.ajaxtocco.com](http://www.ajaxtocco.com)

ERS Engineering Corp.  
6346 Orchard Lake Road  
Suite 103  
West Bloomfield, MI 48322  
Phone: (248) 538-9082  
Fax: (248) 538-9486  
[info@ersengine.com](mailto:info@ersengine.com)  
[www.ersengine.com](http://www.ersengine.com)

Inductoheat Inc.  
32551 N. Avis Dr.  
Madison Heights, MI 48071  
Phone: (248) 585-9393  
Fax: (248) 589-1062  
[sales@inductoheat.com](mailto:sales@inductoheat.com)  
[www.inductoheat.com](http://www.inductoheat.com)

The evolution of  
**GEAR SHAVING**

RASO 200 - RASO 400 - RASO 600 - RASO 250 Twin Power  
A complete range of gear shaving machines for  
advanced gear manufacturing  
[www.sicmat.com](http://www.sicmat.com)

Agents for U.S. and Canada: Star SU LLC  
5200 Prairie Stone Parkway, Suite 100  
Hoffman Estates, IL 60192  
[www.star-su.com](http://www.star-su.com)

**SICMAT**  
MACHINE TOOLS SINCE 1932

**Star SU**